

# Specifications

MODELS		GS™-1930	
MEASUREMENTS		US	Metric
Working height maximum*		25 ft	7.79 m
<b>A</b>	Platform height maximum	19 ft	5.79 m
<b>B</b>	Platform height stowed	3 ft 3.5 in	1.00 m
<b>C</b>	Platform length - outside	5 ft 4 in	1.63 m
	extended	8 ft 4 in	2.54 m
Slide-out platform extension deck		3 ft	.91 m
<b>D</b>	Platform width - outside	2 ft 5 in	.74 m
Guardrail height: fixed rails		3 ft 3 in	.99 m
	fold down (CE)	3 ft 7 in	1.10 m
Toeboard height		6 in	.15 m
<b>E</b>	Height - stowed: fixed rails	6 ft 7 in	2.00 m
	folding guardrails (CE)	6 ft 11 in	2.11 m
	rails folded	5 ft 9 in	1.75 m
<b>F</b>	Length - stowed	6 ft	1.83 m
	Length - stowed extended	9 ft	2.74 m
<b>G</b>	Width	2 ft 6 in	.76 m
<b>H</b>	Wheelbase	4 ft 4 in	1.32 m
<b>I</b>	Ground clearance - center	2.4 in	.06 m
<b>J</b>	- with pothole guards deployed	.75 in	.02 m

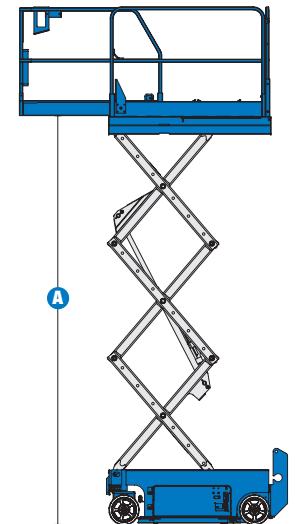
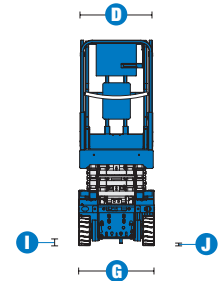
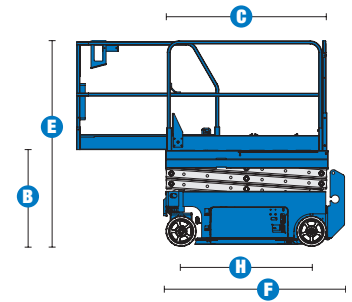

PRODUCTIVITY			
Maximum platform occupancy**		2	2
Lift capacity		500 lbs	227 kg
Lift capacity - extension deck		250 lbs	113 kg
Drive speed - stowed		2.5 mph	4.0 km/h
Drive speed - raised		0.5 mph	0.8 km/h
Gradeability - stowed***		30%	
Turning radius - inside		zero	zero
Turning radius - outside		5 ft 1 in	1.55 m
Raise / lower speed		16 / 25 sec	16 / 25 sec
Controls		proportional	
Drive		dual front wheel	
Multiple disc brakes		dual rear wheel	
Tires - solid non-marking		12 x 4.5 x 8 in	30 x 11 x 20 cm

POWER			
Power source		24 V DC (four 6 V 225 Ah batteries)	
Hydraulic system capacity		3.75 gal	14.2 L

WEIGHT****			
ANSI, CSA		2,702 lbs	1,226 kg
CE indoor		3,302 lbs	1,498 kg
AUS indoor		3,302 lbs	1,498 kg